

**Whole Family**

KVF-XXXXX-TDWJ 12V 24VDC  
30W 60W 80W 96W 100W  
120W 150W 200W 300W

**FC Class 2 Class P**
**■Features**

- Output constant voltage
- UL, cUL listed, Class 2, Class P, Type HL
- Universal AC input: 100-277VAC
- Power Factor: up to 0.98
- High efficiency : up to 83%
- Dimming range: 0-100%
- Load: 10-100%
- Protection:short circuit/over loading/ Over temperature
- PWM output, does not change the color index
- Full protection aluminum housing, for dry, damp location
- Flicker-free
- Compatible with Forward phase, Reverse phase, Triac, MLV, ELV Dimmers
- Cooling by free air convection
- Suitable for LED lighting and moving sign applications

**■Specification**

| Model        |                                 | KVF-12060-TDWJ  | KVF-24060-TDWJ          |
|--------------|---------------------------------|---|-------------------------|
| Certificates |                                 | FCC UL cUL Class 2  | FCC UL cUL Class 2      |
| Output       | DC Voltage                      | 12V   | 24V                     |
|              | Rated Current                   | 5A  | 2.5A                    |
|              | Rated Power                     | 60W   |                         |
|              | Voltage Tolerance               | ±0.5V   |                         |
|              | Voltage Regulation              | ±0.5%   |                         |
|              | Load Regulation                 | ±1%   |                         |
| Input        | Voltage Range                   | 100-277VAC  |                         |
|              | Frequency Range                 | 47-63Hz   |                         |
|              | Power Factor (Typ.) @ full load | 0.98@120VAC 0.95@277VAC   | 0.98@120VAC 0.95@277VAC |
|              | THD (Typ.) @ full load          | <20%  |                         |
|              | Efficiency (Typ.) @ full load   | 83%   | 83%                     |
|              | AC Current (Max.)               | 0.9A@100VAC   |                         |
|              | Inrush Current (Typ.)           | 14A, 50%, 780us   |                         |
|              | Leakage current                 | <0.50mA   |                         |
| Protection   | Short Circuit                   | shut down o/p voltage, re-power on to recover after fault condition removed |                         |
|              | Over Loading                    | ≤120% Hiccup mode,recovers automatically after fault condition is removed   |                         |
|              | Over temperature                | 100°C±10°C shut down o/p voltage, automatically recover after cooling.      |                         |
| Environment  | Working TEMP.                   | -40~+60°C (see below derating curve)  |                         |
|              | Working Humidity                | 20~90%RH, non-condensing  |                         |
|              | Storage TEMP. Humidity          | -40~+80°C, 10~95%RH   |                         |
|              | TEMP .coefficient               | ±0.03%/°C (0~50°C)  |                         |
|              | Vibration                       | 10~500Hz, 5G 10min./1 cycle,period for 60min. each along X,Y,Z axes         |                         |
| Safety& EMC  | Safety standards                | UL8750+UL1310   |                         |
|              | Withstand voltage               | I/P-O/P:1.88KVAC  |                         |
|              | Isolation resistance            | I/P-O/P:100MΩ/500VDC/25°C/70%RH   |                         |
|              | EMC EMISSION                    | FCC Part 15 B   |                         |
| others       | Net. Weight                     | 1.1Kg   |                         |
|              | Size                            | 188*92*26mm (L*W*H)   |                         |
|              | packing                         | 10PCS/CTN   |                         |

## Phase cut /Triac dimmable driver-PWM output KVF-TDWJ series 60W

|              |   |
|--------------|---|
| <b>Notes</b> | <p>1. All parameters if NOT specially mentioned are measured at 120VAC input , rated load and 25°C of ambient temperature.</p> <p>2. To extend the driver's using life ,please reduce the loading at lower input voltage.</p> |
|--------------|---|

### Derating Curve

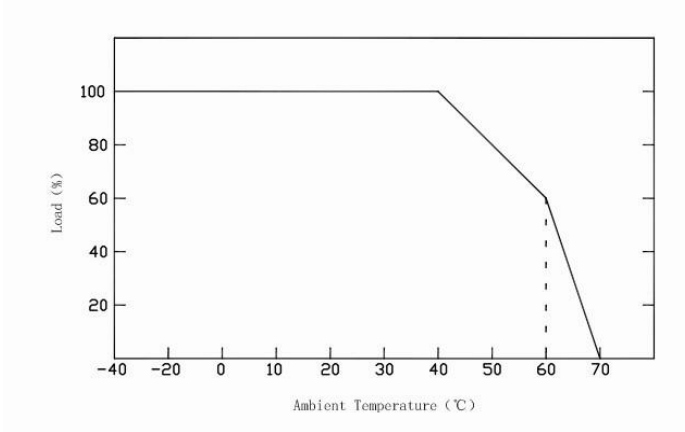

※To extend their life, please refer to the Derating Curve and derate according to the temperature.

### Mechanical Specification

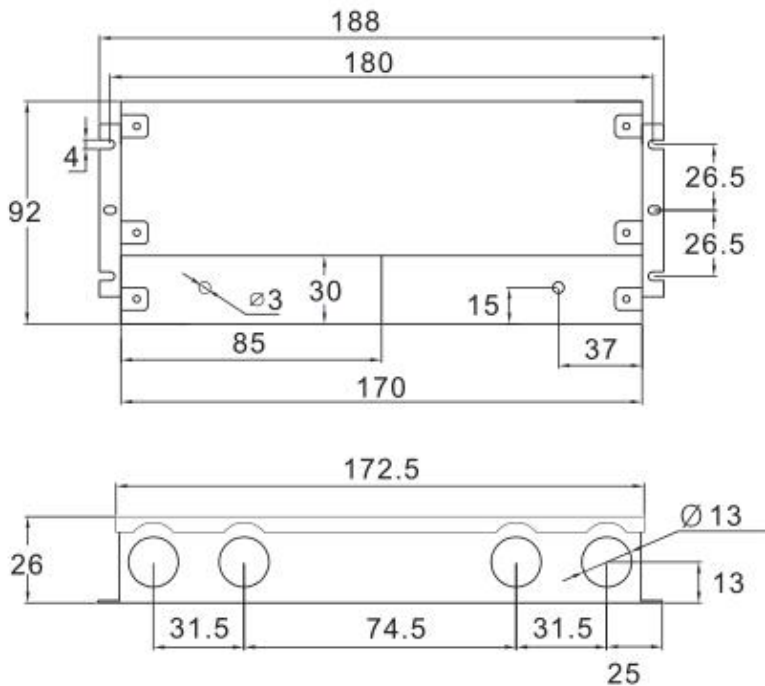

Unite: mm  
Tolerance:P 0.5-2mm

- ※ Input wire 18AWG Black and White to be connected to AC L and N ,Green wire go ground,
- ※ Output wire 18AWG Red to LED Positive side (+) , Black to LED Negative side (-).

### Dimming Operation

- ※The Pulse-Width Modulation (PWM) of output voltage can be adjusted through input terminal of the AC phase line(L) by connection a phase/triac dimmer.
- ※Usually matching with Forward phase , leading edge , Magnetic low voltage, triac dimmers, or Reverse phase, trailing edge ,Electric low voltage Dimmers.

※Please try to use dimmers with power at least 1.5 times as the output power of the driver.

■ Connecting Diagram

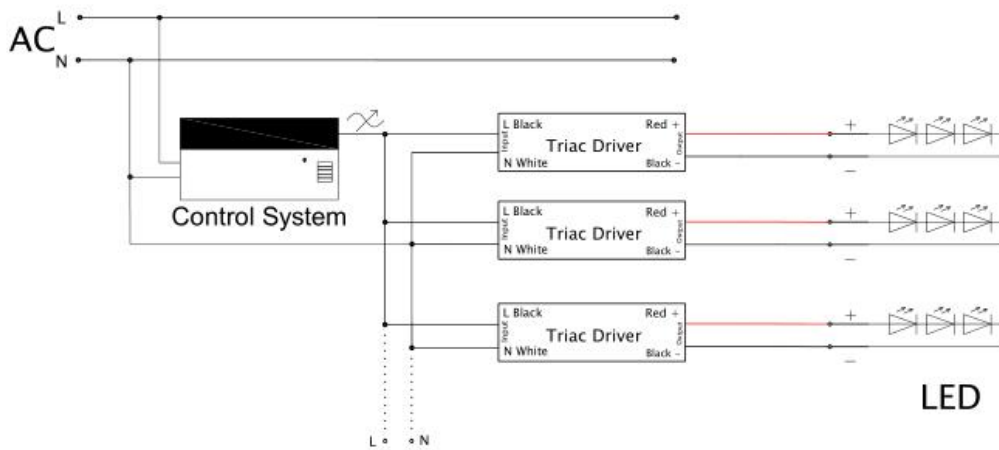
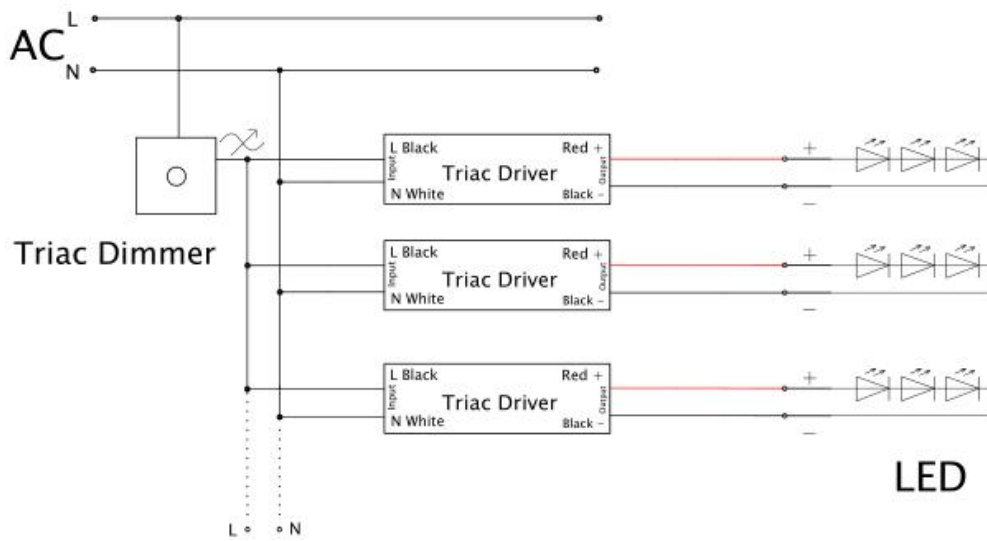
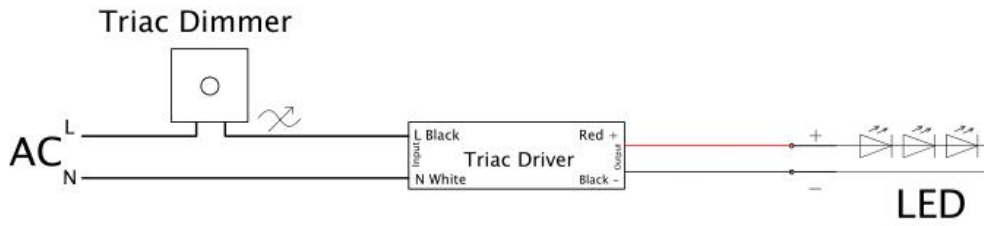

■ Instruction:

- 1) This driver should be installed by qualified and professional person;
- 2) Please make sure the driver is installed with adequate ventilation around it to allow for heat dissipation.
- 3) Ensure that wiring is correct before test in order to avoid light and power supply damage;
- 4) If driver Cannot work normally, don't maintain privately;